



Terms and Conditions

1. Deposit each skip on the highway in the location described on the individual site application and signed and guarded in accordance with the diagrams shown in Schedule 1 below. Position the skip so that its longer sides are parallel to the edge of the carriageway and as near to the edge of the carriageway as is reasonably practicable in such a way that it does not impede the surface water drainage of the highway nor obstruct access to any manhole or the apparatus of any undertaker as defined in the New Roads and Street Works Act 1991. All skips will comply with the Builders Skips (Markings) Regulations 1984.
2. Ensure that where more than one skip is on the highway at any one time the skips shall be positioned as closely as possible to each other so as not to obstruct access to any premises unless the consent of the occupier of those premises has been obtained.
3. Ensure that each skip is clearly and indelibly marked with the owner's name and with his telephone number or address.
4. Each skip shall not exceed 5 metres in length by 2 metres in width.
5. Ensure that each skip or group of skips, whilst on the highway, is marked, guarded and lit in accordance with the following requirements:
 - a) The ends of each skip (that is to say, the side of the skip facing the traffic in both directions when the skip is positioned as mentioned in condition 1 above) shall be painted yellow and there shall be fitted markings which comply with the Builders Skips (Markings) Regulations 1984.
 - b) The painting and the markings shall be kept clean at all times.
 - c) Each skip where placed on the carriageway shall be guarded by at least 4 traffic cones placed on the carriageway in an oblique line on the approach side of the skip.
 - d) Where 2 or more skips are deposited in a row, so that the distance between adjacent skips does not exceed 2 metres, the row shall be guarded as if it were one skip.
 - e) At night (that is to say, between half an hour before sunset and half an hour after sunrise) in accordance with Regulation 43 of the Traffic Signs Regulations and General Direction 1994, lamps complying with BS 3143 shall be placed against or attached to each corner of the skip or the end corners of the row of skips where two or more skips are deposited in a row and the distance between adjacent skips does not exceed 2 metres. They shall also be placed between each cone and shall remain lit throughout the night.
 - f) Failure to ensure the correct signing and guarding of the skips at all times may result in withholding of future skip permits.
6. No skip, when standing in the highway, shall contain any inflammable, explosive, noxious or dangerous material, or any material which is likely to putrefy, or which otherwise is, or is likely to become, a nuisance to users of the highway or residents to the area.
7. No skip shall be used in such a way that any of its contents fall on to the highway or that there is an escape of dust from the contents of the skip when standing in the highway.
8. Ensure that each skip shall be removed for emptying as soon as practicable and in any case not later than 2 working days after it has been filled.
9. No skip shall remain on the highway after the period of this licence has expired.

10. Properly dispose of all materials and leave the highway where the skip or skips have been deposited in a clean and tidy condition, when the skips have been removed, or, on the expiration of this permission.

11. Although permission can be given, the County Council or the Police can require the skip to be removed or repositioned and recover the costs.

12. The County Council must be indemnified against all accident claims costs and liabilities, which may arise from or be attributable to the presence of the skip hereby licensed.

13. Skips placed on the highway without the permission of Norfolk County Council may be removed by them and all reasonable costs recovered. In any case where any unlicensed skips are found on the highway an additional fee will be charged to reflect the additional administration and inspection costs that will have been incurred.

14. I shall complete the application form giving 7 days' notice of my request to deposit a skip on the highway and pay the application fee, in advance, for each application for a licence lasting no longer than 28 days. Any extension to this licence will be made towards the end of the 28-day period at the renewal rate.

15. These terms and conditions are designed to inform you of the basic requirements of placing a Skip(s) on a footway, road or verge. They do not necessarily cover your entire liability and you are responsible for ensuring that you comply with the Law.

Schedule 1 Norfolk County Council Builder's Skips on the highway
Norfolk County Council
Builder's Skips on the highway

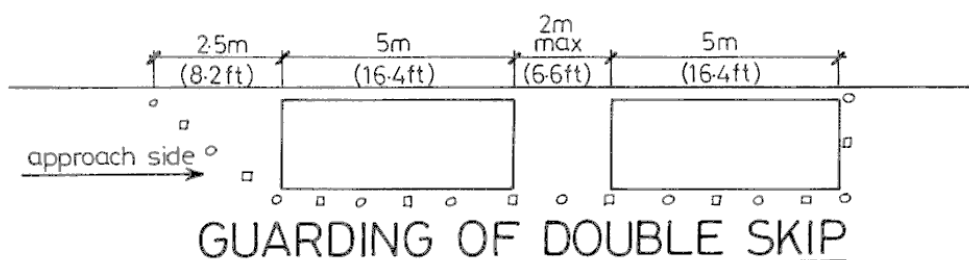
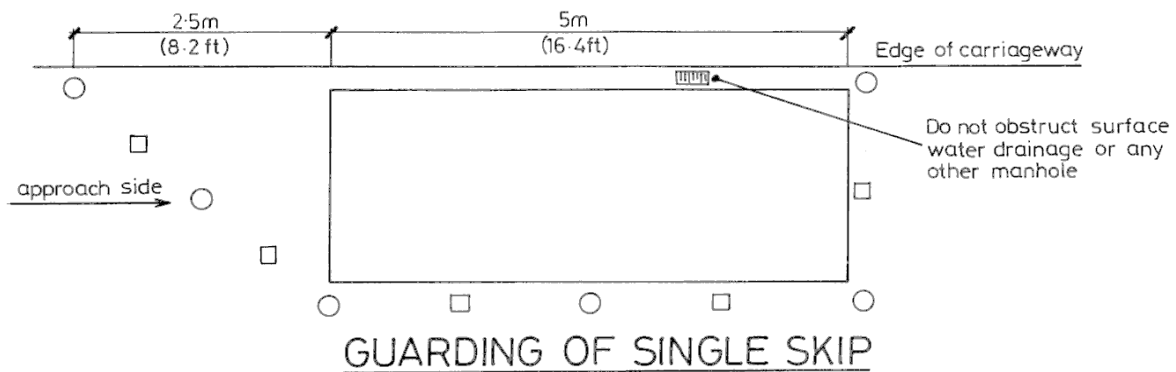

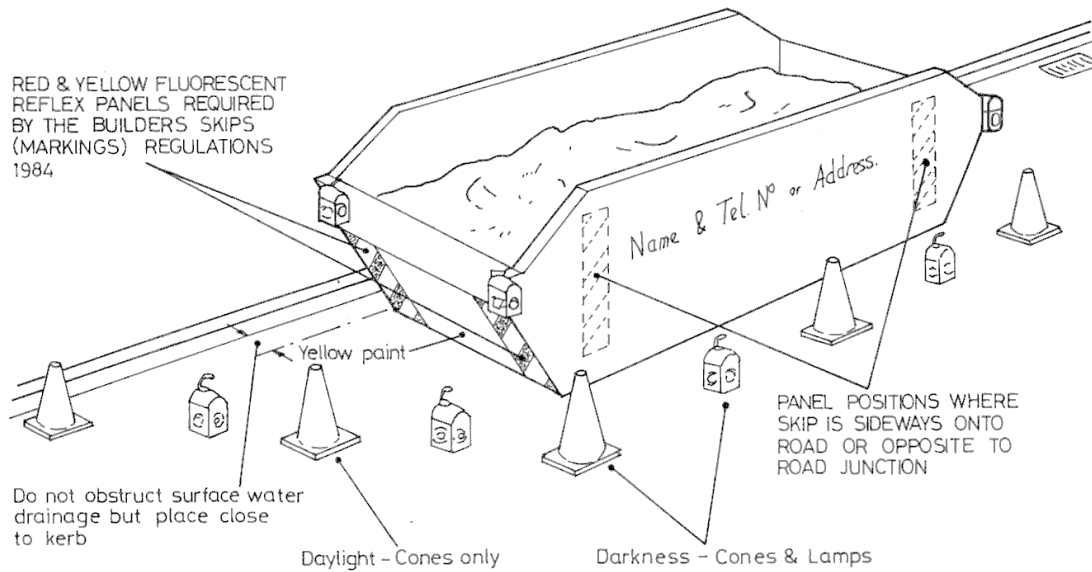

The builders skip (marking regulations 1984) Specification about design

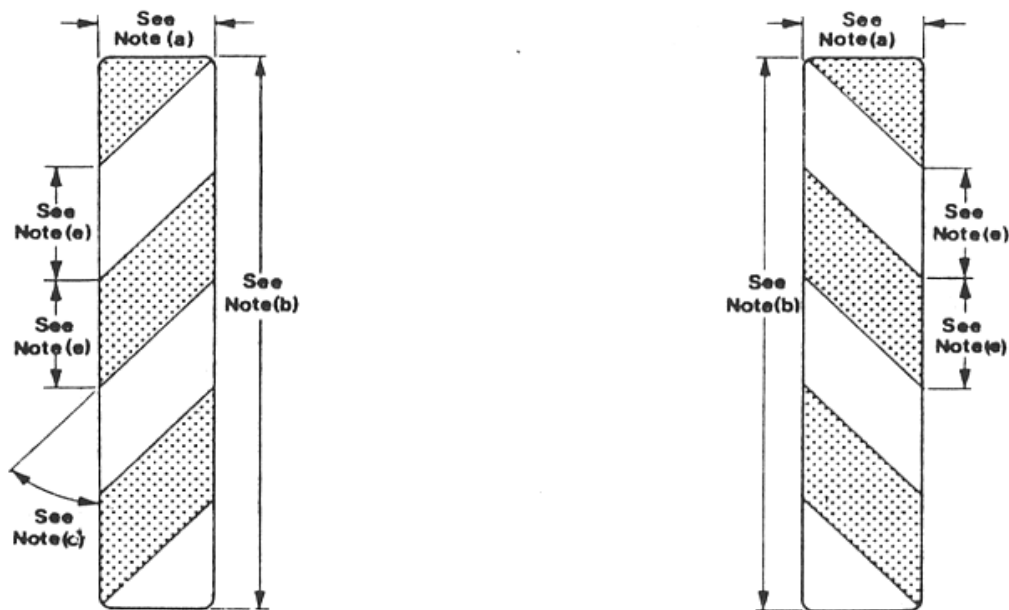

Notes:-

- a The width of each half of the marking shall be neither less than 140 millimetres nor more than 280 millimetres.
- b The length of each half of the marking shall be neither less than 350 millimetres nor more than 700 millimetres.
- c The angle of each stripe shall be not less than 40 degrees to neither the vertical nor more than 50 degrees to the vertical.
- d Each half of the marking shall have a minimum area of 980 square centimetres.
- e The breadth of each stripe shall be neither less than 133 millimetres nor more than 147 millimetres.